

PLAN

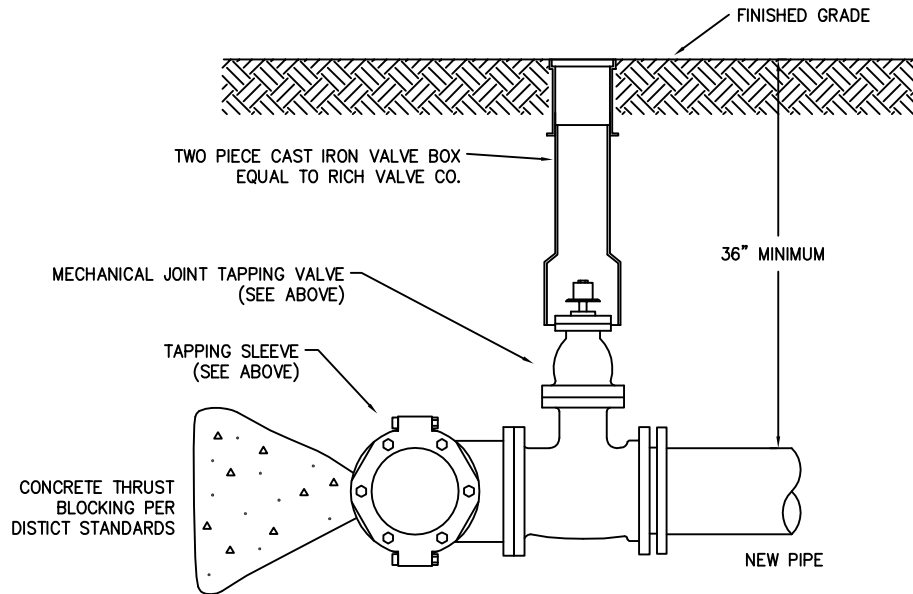

ELEVATION

- NOTES:
1. PRIOR TO BORING:
 - A. TAPPING SLEEVE AND VALVE SHALL BE PRESSURE TESTED AT 225 PSI FOR A PERIOD OF 15 MINUTES. PRESSURE LOSS DURING TESTING SHALL NOT EXCEED 5 PSI.
 - B. TAPPING SLEEVE AND VALVE SHALL BE STERILIZED PER SPECIFICATIONS
 2. PRIOR TO FINAL CONNECTION OF TAPPING VALVE TO NEW PIPING, THE NEW PIPING SHALL BE PRESSURE TESTED AND STERILIZED PER SPECIFICATIONS

WET TAP DETAIL

WATER STANDARD DETAIL
NORTHEAST SAMMAMISH
SEWER AND WATER DISTRICT

FILE	SCALE	DATE
SAMDTW21	NTS	3/2/93